

PHYSICS

- The percentage errors in the measurement of time period and length of a simple pendulum are 2% and 1%. The percentage error in the determination of acceleration due to gravity at the place is  
A) 3%                      B) 4%                      C) 5%                      D) 6%                      E) 8%
- The number of significant figures in the result of  $\frac{(25.17 + 4.683) \times 10^{-4}}{7.6 \times 10^9}$  is  
A) 1                      B) 2                      C) 3                      D) 4                      E) 5
- The velocity of a particle moving along +x- direction is given by  $v = k\sqrt{x}$ , where x is the position of the particle. Then, the relation between acceleration a and velocity v of the particle is  
A)  $a \propto v^0$                       B)  $a \propto v$                       C)  $a \propto v^{-1/2}$                       D)  $a \propto v^{3/2}$                       E)  $a \propto v^{-3/2}$
- A particle thrown vertically upwards with a speed u goes up to a maximum height h. By what percentage the velocity has to be increased so as to double the maximum height?  
A) 100%                      B) 75%                      C) 63.2%                      D) 50%                      E) 41.4%
- If  $\vec{A}$  and  $\vec{B}$  are two non- zero vectors, then find  $(\vec{A} + \vec{B}) \cdot (\vec{A} \times \vec{B})$   
A)  $A^2 + B^2$                       B) AB                      C)  $A^2 - B^2$   
D)  $(A + B)^3$                       E) Zero
- A ball of mass m is projected obliquely from the ground at  $t=0$ . At  $t=4s$ , the velocity of the ball is given by  $\vec{v} = (6\hat{i} - 8\hat{j})$  m/s. Then, identify the correct statement.  
A) The horizontal distance travelled by the ball in  $t=4s$  is 16 m  
B) The ball has passed the highest point on its trajectory within  $t=4s$   
C) The velocity of projection of the ball is  $(6\hat{i} + 24\hat{j})$  m / s  
D) The angle of projection with respect to horizontal is  $\tan^{-1}\left(\frac{3}{4}\right)$   
E) The ball returns to the ground at  $t=5.6s$
- A trunk of mass m, placed on top of a rough plane inclined at an angle  $\theta$  with horizontal. If the coefficient of friction between the trunk and the plane is  $\mu$ , then the minimum value of  $\theta$  for which the trunk starts sliding on the plane is  
A)  $\sin^{-1}(\mu)$                       B)  $\cos^{-1}(\mu)$                       C)  $\tan^{-1}(\mu)$   
D)  $2 \tan^{-1}(\mu)$                       E)  $2 \sin^{-1}(\mu)$

8. If the system is released, find the tension in the string connecting blocks B and C (Take  $g = 10 \text{ m/s}^2$ )

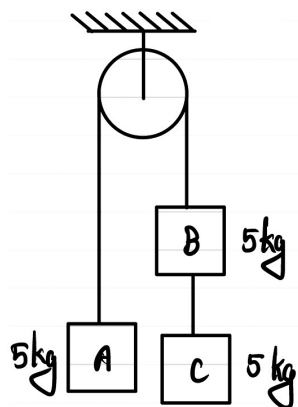

- A) 21.67 N      B) 33.33 N      C) 41.07 N      D) 52.14 N      E) 66.67 N
9. A block of mass  $m$  is released from a height  $h$  over a frictionless ramp. The coefficient of friction between the block and the level surface is  $\mu$ . The distance  $x$  travelled by the block on the level surface before it comes to rest is

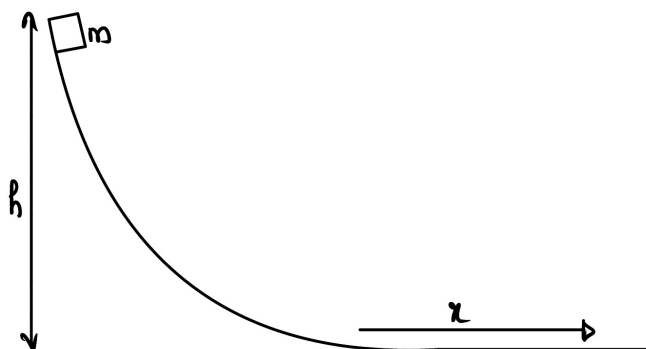

- A)  $\frac{h}{2\mu}$       B)  $\frac{2h}{\mu}$       C)  $\mu h$       D)  $\frac{\mu h}{2}$       E)  $\frac{h}{\mu}$
10. A block of mass  $m$  is attached to a light spring of force constant  $k$ . If the block is given an impulse  $J$ , the maximum compression of spring is

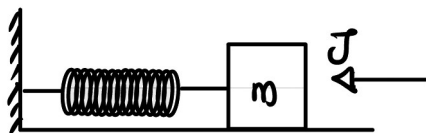

- A)  $\frac{J}{km}$       B)  $\frac{J}{\sqrt{km}}$       C)  $\frac{J^2}{km}$
- D)  $\frac{Jm}{k}$       E)  $\frac{Jm}{k^2}$

11. Two identical rods of mass  $m$  and length  $\ell$  form a v-shaped structure as shown in the figure. The moment of inertia of the system about an axis passing through O and perpendicular to the plane of rods is

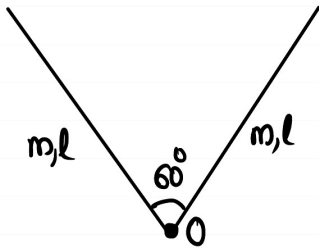

- A)  $\frac{m\ell^2}{3}$       B)  $\frac{m\ell^2}{12}$       C)  $\frac{3m\ell^2}{4}$       D)  $\frac{m\ell^2}{6}$       E)  $\frac{2m\ell^2}{3}$
12. A uniform sphere of density  $\rho$  and radius  $R$  rotates with an angular speed  $\omega$  about an axis passing through its diameter. The rotational kinetic energy of the sphere about the axis of rotation is
- A)  $\frac{4}{15} \pi R^5 \rho \omega^2$       B)  $\frac{4}{3} \pi R^5 \rho \omega^2$       C)  $\frac{5}{12} \pi R^5 \rho \omega^2$       D)  $\frac{2}{7} \pi R^5 \rho \omega^2$       E)  $\frac{14}{3} \pi R^5 \rho \omega^2$
13. A ball of mass  $m$  is dropped from a height  $R$  from the surface of Earth ( $R$  being the radius of Earth). If  $g$  is the acceleration due to gravity on Earth's surface, then the speed with which the ball hits the surface is
- A)  $\sqrt{2gR}$       B)  $\sqrt{\frac{gR}{2}}$       C)  $\sqrt{\frac{gR}{3}}$       D)  $\sqrt{gR}$       E)  $\sqrt{\frac{gR}{6}}$
14. Which of the following graphs shows the correct variation of acceleration due to gravity  $g$  with radial distance  $r$  from the centre of Earth? ( $R$  is the radius of Earth)

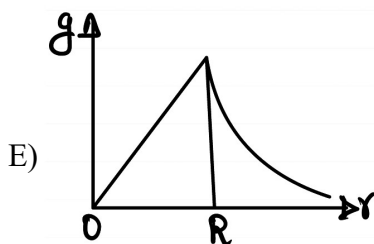
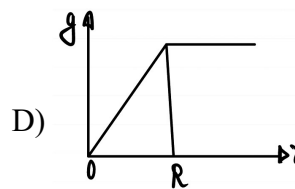
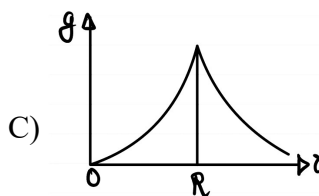
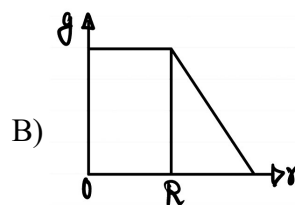
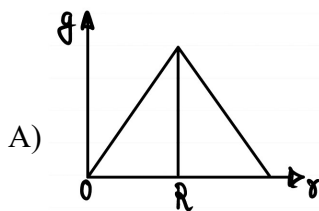

15. The stress- strain graph of two materials A and B is shown in the figure

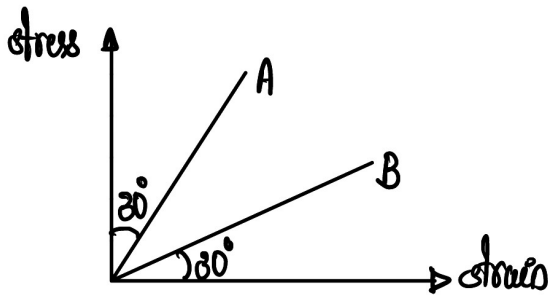

If  $Y_A$  and  $Y_B$  are the youngs moduli of the materials A and B , respectively, then

- A)  $Y_A = Y_B$       B)  $Y_A Y_B = 1$       C)  $Y_A Y_B = 3$       D)  $\frac{Y_A}{Y_B} = 3$       E)  $Y_A = \sqrt{3} Y_B$

16. The following graph shows the relation between a linear scale of temperature called the X- scale and Celsius scale

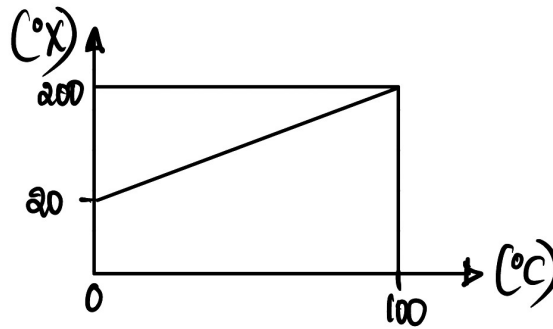

The temperature reading at which both scales show the same reading is

- A) 5°C, 5°X      B) -10°C, -10°X      C) -5°C, -5°X      D) 15°C, 15°X      E) -25°C, -25°X
17. One mole of an ideal monatomic gas undergoes a thermodynamic process from A to B as shown in the P-V diagram

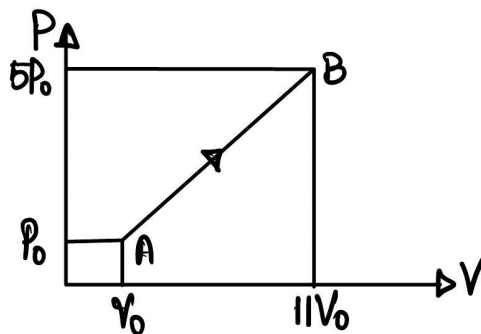

The heat capacity of the gas during the process is

- A)  $\frac{11R}{7}$       B)  $\frac{47R}{11}$       C)  $\frac{55R}{27}$       D)  $\frac{101R}{54}$       E)  $\frac{110R}{19}$

18. If the rms speed of hydrogen molecules at NTP is  $v$ , the rms speed of oxygen molecules at NTP is

- A)  $v$                       B)  $2v$                       C)  $\frac{v}{2}$                       D)  $4v$                       E)  $\frac{v}{4}$

19. The variation of potential energy of a simple harmonic oscillator with displacement from mean position is shown below.

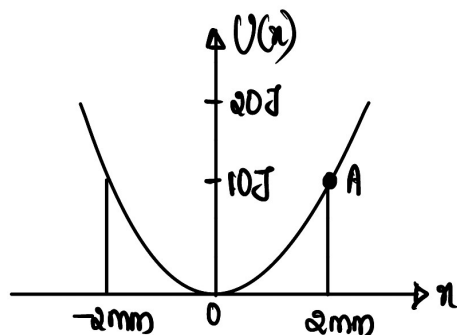

The particle is released from point A in the graph. The force constant of the oscillator (in kN/m) is

- A) 500                                      B) 5                                      C) 5000  
 D) 25                                      E) 2500

20. The equation of a standing wave formed in a closed organ pipe of length 2m is given by

$y(x, t) = 4 \sin(\pi x / 80) \cos(400\pi t)$  where  $x$  and  $y$  are in cm and  $t$  is in seconds. The number of nodes formed is

- A) 1                                      B) 2                                      C) 3  
 D) 4                                      E) 5

21. Two sound waves, given by  $y_1 = 2 \sin(100\pi t)$  and  $y_2 = 3 \sin(108\pi t)$ , interfere at  $x=0$ . The time period of variation of intensity is

- A) 1s                                      B) 0.5 s                                      C) 2s  
 D) 0.75 s                                      E) 0.25 s

22. Figure below shows two concentric spheres A and B. A encloses a point charge  $q$  and the flux through A is  $\phi$ . If the flux through B is  $-\phi$ , the charge present in the region between A and B is

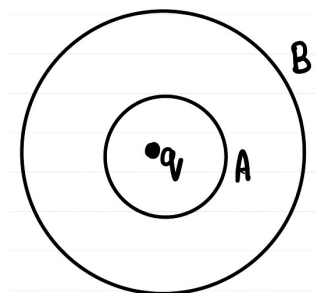

- A) zero                      B)  $q$                       C)  $-q$                       D)  $2q$                       E)  $-2q$

23. A point dipole of dipole moment  $\vec{p}$  is placed in a non-uniform electric field as shown in the figure. The dipole will experience

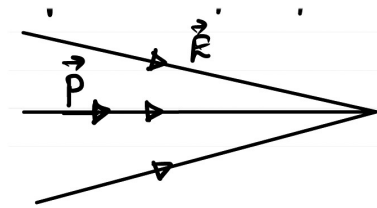

- A) Zero net force  
 B) net force towards right  
 C) net force towards left  
 D) net torque clockwise  
 E) net torque anticlockwise
24. A uniform electric field  $\vec{E} = 20\hat{i} \text{ V/m}$  exists in a region. The potential difference  $V_A - V_B$  between points  $A(-3,2,0)$  and  $B(2,4,1)$  is
- A) 10 V  
 B) 20 V  
 C) 100 V  
 D) -100 V  
 E) -50 V
25. Consider the following network of identical capacitors, each having capacitance  $C$ .

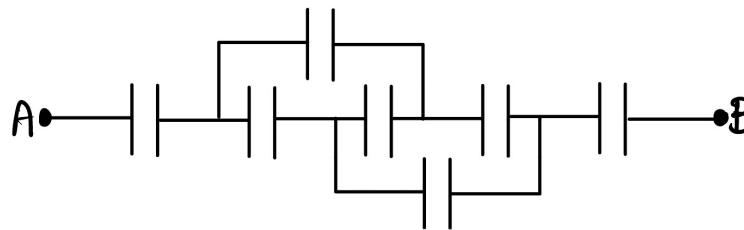

The equivalent capacitance across A and B is

- A)  $C$   
 B)  $2C$   
 C)  $2C/3$   
 D)  $3C$   
 E)  $3C/2$
26. The equivalent resistance across A and B is

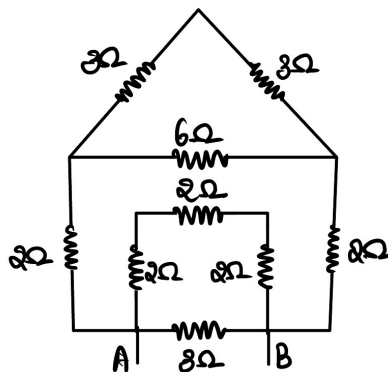

- A)  $\frac{14}{9}\Omega$   
 B)  $\frac{2}{3}\Omega$   
 C)  $\frac{3}{2}\Omega$   
 D)  $\frac{5}{6}\Omega$   
 E)  $\frac{6}{5}\Omega$

27. In the circuit shown, the potential difference  $V_A - V_B$  between points A and B is

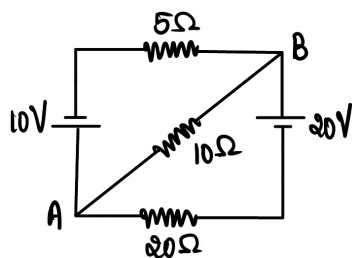

- A) 10 V
- B) -8.6 V
- C) 8.6 V
- D) -10 V
- E) Zero

28. The conductivity of a metal wire is

- A) directly proportional to drift velocity of free electrons
- B) inversely proportional to cross-sectional area of wire
- C) inversely proportional to length of wire
- D) directly proportional to electric field in the wire
- E) directly proportional to relaxation time of free electrons.

29. A charged particle moves through a region with constant velocity. If E and B are the magnitudes of possible electric and magnetic fields in the region, which of the following scenarios are possible?

- i)  $E = 0$  and  $B = 0$
  - ii)  $E \neq 0$  and  $B = 0$
  - iii)  $E = 0$  and  $B \neq 0$
  - iv)  $E \neq 0$  and  $B \neq 0$
- A) i only
  - B) i and iii only
  - C) i, iii and iv only
  - D) iii and iv only
  - E) iv only

30. The magnetic dipole moment of the following current-carrying loop AOBCEA is  $x \times 10^{-2} \text{ A.m}^2$ . The value of x is

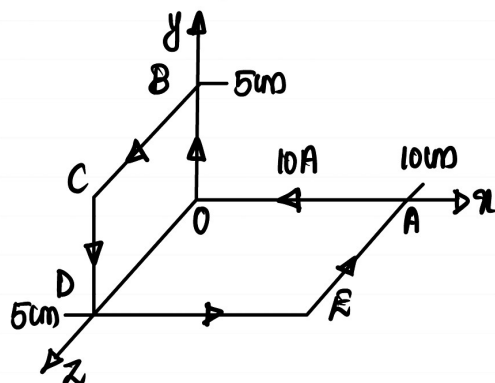

- A)  $\frac{5\sqrt{5}}{2}$
- B)  $5\sqrt{2}$
- C) 5
- D)  $2\sqrt{5}$
- E) 10



35. A cell of emf 20 V is connected to a coil of inductance 2 mH and resistance 100  $\Omega$ . The magnetic energy stored in the coil in steady state condition is
- A)  $4 \times 10^{-5}$  J      B)  $2 \times 10^{-5}$  J      C)  $2 \times 10^{-3}$  J      D)  $2 \times 10^{-6}$  J      E) Zero
36. A series LCR circuit with  $R = 200 \Omega$ ,  $L = 20$  H and  $C = 20 \mu\text{F}$  is connected to a 200 V AC supply. Choose the correct statement.
- A) The angular frequency of AC source is 50 rad/s  
B) An ammeter connected in circuit measures 1 A current  
C) A voltmeter connected across R measures 200 V  
D) The power factor of the circuit is unity  
E) All of the above
37. A step-up transformer working on 2 kW power has a turn ratio of 2:5. The voltage across secondary for a primary voltage of 100 V is
- A) 500 V      B) 200 V      C) 250 V      D) 300 V      E) 400 V
38. X-rays travel at a speed of  $2 \times 10^8$  m/s through a non-magnetic medium. The dielectric constant of the medium is
- A)  $\frac{3}{2}$       B)  $\frac{9}{4}$       C) 4      D) 2      E) 3
39. A ray of light passing through a prism of refractive index  $\sqrt{2}$  suffers minimum deviation. It is found that the angle of incidence is double the angle the angle of refraction inside the prism. The refracting angle of the prism is
- A)  $15^\circ$       B)  $30^\circ$       C)  $45^\circ$       D)  $60^\circ$       E)  $90^\circ$
40. Two polaroids are crossed to each other. If one of them is rotated through  $60^\circ$ , then what percentage of the incident unpolarised light will be transmitted by the polaroids?
- A) 10%      B) 37.5%      C) 45%      D) 60%      E) 75%
41. The kinetic energy of electron is E when the incident light has wavelength  $\lambda$ . To increase the KE to 2E, the incident light must have wavelength
- A)  $\frac{hc\lambda}{E\lambda + hc}$       B)  $\frac{h\lambda}{E + hc}$       C)  $\frac{E\lambda}{hc + \lambda}$   
D)  $\frac{\lambda}{2}$       E)  $\frac{2hc}{E\lambda}$
42. The ratio of longest wavelength to the shortest wavelength in the Balmer series of hydrogen spectrum is
- A)  $\frac{4}{3}$       B)  $\frac{16}{9}$       C)  $\frac{81}{25}$       D)  $\frac{9}{5}$       E) Infinity
43. Which of the following is not a property of nuclear force?
- A) charge independent      B) spin dependent      C) Non-control  
D) Exchange force      E) Long-ranged



51. Electrode potential for Mg electrode varies according to the equation

$$E_{\text{Mg}^{2+}|\text{Mg}} = E_{\text{Mg}^{2+}|\text{Mg}}^{\ominus} - \frac{0.059}{2} \log \frac{1}{[\text{Mg}^{2+}]}. \text{ The graph of } E_{\text{Mg}^{2+}|\text{Mg}} \text{ vs } \log [\text{Mg}^{2+}] \text{ is}$$

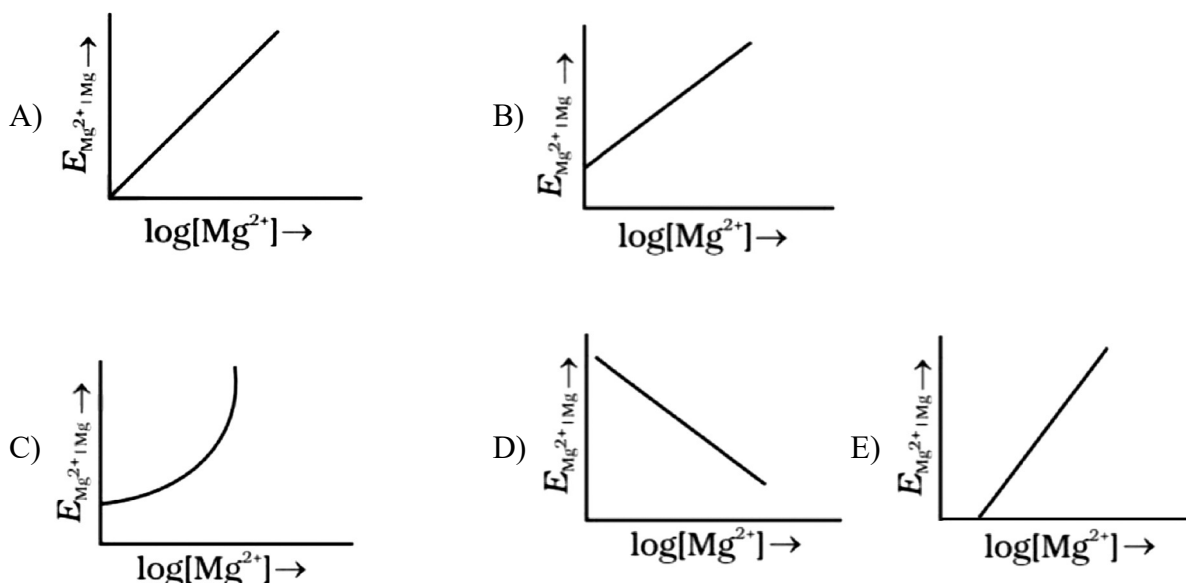

52. Which of the following is not an important condition for salient feature of hybridisation?

- A) The orbitals present in the valence shell of the atom are hybridised
- B) The orbitals undergoing hybridisation should have almost equal energy
- C) Promotion of electron is an essential condition prior to hybridisation
- D) It is not necessary that only half filled orbitals participate in hybridisation. In some cases, even filled orbitals of valence shell take part in hybridisation
- E) hybrid orbitals are more effective for bond formation than atomic orbitals

53. Assertion (A):  $\text{PCl}_5$  molecules are more reactive than  $\text{PCl}_3$  molecules

Reason (R): As the axial bond pairs suffer more repulsive interaction from the equatorial bond pairs, therefore axial bonds have been found to be slightly longer and hence slightly weaker than the equatorial bonds

- A) A is not correct but R is correct
- B) A is correct but R is not correct
- C) Both A and R are correct and R is the correct explanation of A
- D) Both A and R are correct but R is not the correct explanation of A
- E) A and R are incorrect

54. Among the following acidic, neutral and amphoteric oxides respectively are given as

- A)  $\text{GeO}_2$ ,  $\text{N}_2\text{O}$ ,  $\text{As}_2\text{O}_3$
- B)  $\text{GeO}$ ,  $\text{Al}_2\text{O}_3$ ,  $\text{CO}$
- C)  $\text{PbO}_2$ ,  $\text{NO}$ ,  $\text{CO}_2$
- D)  $\text{SnO}_2$ ,  $\text{CO}$ ,  $\text{Al}_2\text{O}_3$
- E)  $\text{N}_2\text{O}_5$ ,  $\text{SO}_2$ ,  $\text{PbO}$

55.  $\Delta_r G^\ominus$  for conversion of oxygen to ozone,  $3/2 \text{O}_2(\text{g}) \rightarrow \text{O}_3(\text{g})$  at 298 K. If  $K_p$  for this conversion is  $2.47 \times 10^{-29}$

- A) 1630 kJ/mol
- B) 16300 kJ/mol
- C) 163 kJ/mol
- D) 1.63 kJ/mol
- E) 16.3 kJ/mol

56. The conjugate bases for the following Bronsted acids: HF, H<sub>2</sub>SO<sub>4</sub> and HCO<sub>3</sub><sup>-</sup> respectively are
- A) F<sup>-</sup>, HSO<sub>4</sub><sup>-</sup>, CO<sub>3</sub><sup>2-</sup>                      B) H<sup>+</sup>, SO<sub>4</sub><sup>2-</sup>, CO<sub>3</sub><sup>-</sup>                      C) F<sup>-</sup>, SO<sub>4</sub><sup>2-</sup>, CO<sub>3</sub><sup>2-</sup>
- D) F<sup>-</sup>, SO<sub>3</sub><sup>-</sup>, H<sub>2</sub>CO<sub>3</sub>                      E) H<sup>+</sup>, CO<sub>3</sub><sup>2-</sup>, SO<sub>4</sub><sup>2-</sup>
57. Unified mass is equal to
- A) Mass of 1 atom of carbon                      B) 1/12<sup>th</sup> mass of 1 atom of C-12
- C) Mass of 1 atom of Hydrogen                      D) Mass of one atom of oxygen
- E) All of these
58. The radius of which of the following orbit is same as that of first orbit of hydrogen atom?
- A) He<sup>+</sup> (n = 2)    B) Li<sup>2+</sup> (n = 2)    C) Li<sup>2+</sup> (n = 3)    D) Be<sup>3+</sup> (n = 2)    E) He<sup>+</sup> (n = 4)
59. Which of the following statement is not correct from the view point of molecular orbital theory?
- A) Be<sub>2</sub> is not a stable molecule
- B) He<sub>2</sub> is not stable but He<sub>2</sub><sup>+</sup> is expected to exist
- C) Bond strength of N<sub>2</sub> is maximum amongst the homonuclear diatomic molecules belonging to the second period
- D) The order of energies of molecular orbitals in N<sub>2</sub> molecule is
- $$\sigma 2s < \sigma^* 2s < \sigma 2p_z < (\pi 2p_x = \pi 2p_y) < (\pi^* 2p_x = \pi^* 2p_y) < \sigma^* 2p_z$$
- E) O<sub>2</sub> is a paramagnetic molecule
60. On the basis of thermochemical equations (a), (b) and (c), find out which of the algebraic relationship given in options (A) to (E) is correct?
- a) C(graphite) + O<sub>2</sub>(g) → CO<sub>2</sub>(g); Δ<sub>r</sub>H = x kJ mol<sup>-1</sup>
- b) C(graphite) +  $\frac{1}{2}$ O<sub>2</sub>(g) → CO(g); Δ<sub>r</sub>H = y kJ mol<sup>-1</sup>
- c) CO(g) +  $\frac{1}{2}$ O<sub>2</sub>(g) → CO<sub>2</sub>(g); Δ<sub>r</sub>H = z kJ mol<sup>-1</sup>
- A) z = x + y    B) x = y - z    C) x = y + z    D) y = 2z - x    E) y = x + 2z
61. Consider the reaction
- $$\text{N}_2(\text{g}) + 3\text{H}_2(\text{g}) \rightleftharpoons 2\text{NH}_3(\text{g})$$
- Which of the following is correct, if the total pressure at which the equilibrium is established, is increased without changing the temperature?
- A) Equilibrium constant K will remain same
- B) Equilibrium constant K will decrease
- C) Equilibrium constant K will increase
- D) Equilibrium constant K will increase initially and decrease when pressure is very high
- E) Equilibrium constant K will decrease is a minimum and then increase

62. The IUPAC name for

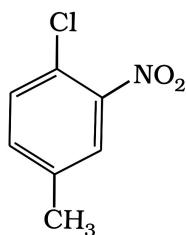

- A) 1-Chloro-2-nitro-4-methylbenzene  
 B) 1-Chloro-4-methyl-2-nitrobenzene  
 C) 2-Chloro-1-nitro-5-methylbenzene  
 D) *m*-Nitro-*p*-chlorotoluene  
 E) *o*-Nitro-chlorobenzene

63. What is the correct order of decreasing stability of the following cations.



I.



II.

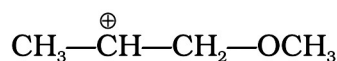

III.

- A) II > I > III  
 B) II > III > I  
 C) III > I > II  
 D) I > II > III  
 E) III > II > I
64. A 'x' colour precipitate, which is y in ammonium hydroxide indicates presence of chlorine identify x and y
- A) x = Yellowish, y = soluble  
 B) x = Yellow, y = insoluble  
 C) x = white, y = insoluble  
 D) x = white, y = soluble  
 E) x = Yellow, y = crystalline
65. When an aromatic primary amine is treated with nitrous acid a compound 'x' is formed. When 'x' is hydrolysed by warming with water the products formed are y, a gas and an acid. The bond order of the gas formed is?
- A) 1  
 B) 2  
 C) 3  
 D) 2.5  
 E) 5
66. The correct increasing order of pK<sub>a</sub> value among the following?  
*o*-Nitrophenol (A), *m*-Nitrophenol (B), *p*-Nitrophenol (C), Phenol (D), *o*-cresol (E), *m*-cresol (F)
- A) C < B < A < D < E < F  
 B) C < A < B < D < E < F  
 C) C < B < D < A < F < E  
 D) C < A < B < D < F < E  
 E) C < D < B < A < F < E

67. Consider the following reactions

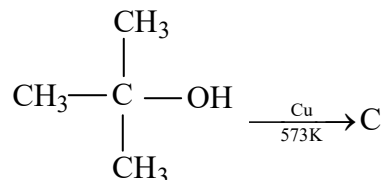
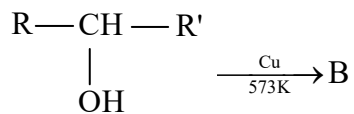
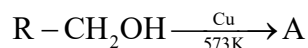

A, B and C respectively are

- A) A → Aldehyde; B → Ketone; C → Acid  
 B) A → Ketone; B → Aldehyde; C → Alkane  
 C) A → Aldehyde; B → Ketone; C → Alkene  
 D) A → Acid; B → Alkene; C → Alkyne  
 E) A → Aldehyde; B → Ammine; C → Acid
68. 3-nitrobromobenzene  $\xrightarrow[ether]{Mg}$  A  $\xrightarrow{Dry\ ice}$  B  $\xrightarrow{H_3O^+}$  C

The product 'C' in this reaction is

- A) Benzoic acid  
 B) 2-nitrobenzoic acid  
 C) 3-nitro benzoic acid  
 D) Terephthalic acid  
 E) Oxalic acid
69. Which of the following properties related to "Diazonium salt" is incorrect?
- A) Benzenediazonium chloride is a colourless crystalline solid  
 B) Benzenediazonium fluoroborate is water soluble and stable at room temperature  
 C) The diazonium salts have the general formula  $RN_2^+X^-$  where R stands for an aryl group and X-ion may be  $Cl^-$ ,  $Br^-$ ,  $HSO_4^-$ ,  $BF_4^-$  etc  
 D) Primary aliphatic amines form highly unstable alkyl diazonium salts  
 E) Diazonium salt is not generally stored. It is used immediately after its preparation
70. Which of the following compounds contains  $\beta - C_1 - C_4$  glycosidic linkage?
- A) Sucrose  
 B) Amylose  
 C) Lactose  
 D) Maltose  
 E) Glucose

71. Assertion: Permanganate titrations in presence of hydrochloric acid are unsatisfactory  
Reason: Hydrochloric acid is oxidised to chlorine by  $\text{KMnO}_4$
- A) A is not correct but R is correct  
B) A is correct but R is not correct  
C) Both A and R are correct and R is the correct explanation of A  
D) Both A and R are correct but R is not the correct explanation of A  
E) Both A and R are incorrect
72. Match List I and List II and pick out correct matching codes from the given choices”

List I

List II

Compound

Structure

A)  $\text{ClF}_3$ 

1) Square planar

B)  $\text{PCl}_5$ 

2) Tetrahedral

C)  $\text{IF}_5$ 

3) Trigonal bipyramidal

D)  $\text{CCl}_4$ 

4) Square pyramidal

E)  $\text{XeF}_4$ 

5) T-shaped

Codes

A) A-5; B-4; C-3; D-2; E-1

B) A-5; B-3; C-4; D-2; E-1

C) A-5; B-3; C-4; D-1; E-2

D) A-4; B-3; C-5; D-2; E-1

E) A-5; B-2; C-4; D-1; E-3

73. Match the columns

**Column I****Column II**A)  $2\text{Mg} + \text{O}_2 \longrightarrow 2\text{MgO}$ 

p) Removal of hydrogen

B)  $\text{Mg} + \text{Cl}_2 \longrightarrow \text{MgCl}_2$ 

q) Removal of electropositive element

C)  $2\text{H}_2\text{S} + \text{O}_2 \longrightarrow 2\text{S} + 2\text{H}_2\text{O}$ 

r) Addition of oxygen

D)  $2\text{K}_4[\text{Fe}(\text{CN})_6] + \text{H}_2\text{O}_2 \rightarrow$   
 $2\text{K}_3[\text{Fe}(\text{CN})_6] + 2\text{KOH}$

s) Addition of electronegative  
 element, chlorine

A) A – (s), B – (q), C – (p), D – (r)

B) A – (r), B – (s), C – (p), D – (q)

C) A – (s), B – (r), C – (q), D – (p)

D) A – (r), B – (p), C – (s), D – (q)

E) A – (r), B – (s), C – (q), D – (p)

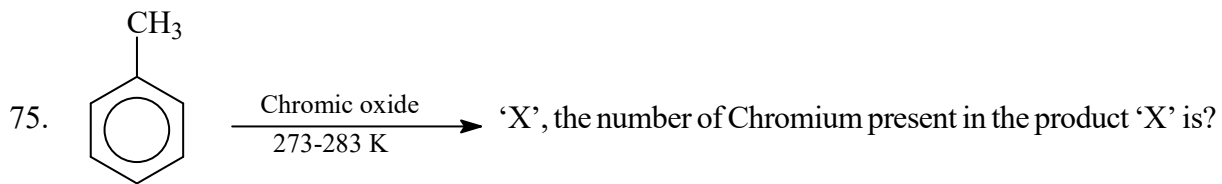
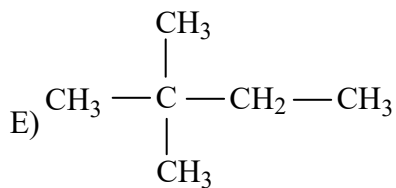
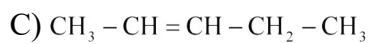
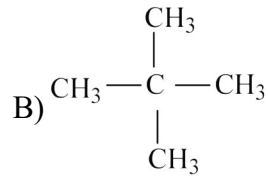
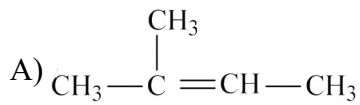
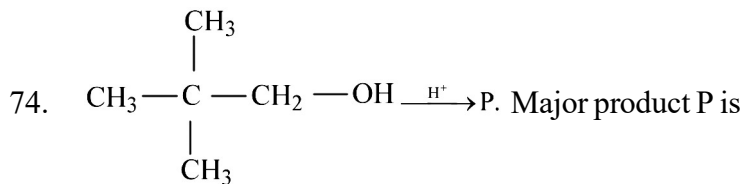

A) 1

B) 2

C) Zero

D) 4

E) 3

### MATHEMATICS

76. If  $A = \{1, 2, a, b, 4\}$  and  $B = \{1, b\}$ . Then  $A - B$  is

A)  $\{2, a, 4\}$

B)  $\{2, a, 4, 1\}$

C)  $\{2, a, b\}$

D)  $\{1, 2, a, b\}$

E)  $\{1, 2, 4\}$

77. Let  $f(x) = x^2 - 1$  and  $g(x) = 4x - 6$ . Then  $f(g(6))$  is

A) 324

B) 35

C) 323

D) 15

E) 18

78. The real part of the complex number  $\frac{1}{1+i}$  is

A) 1

B) 2

C)  $\frac{1}{2}$

D)  $\frac{-1}{2}$

E) 0

79. If  $z = x + iy$  and  $\sqrt{z} = p - iq$ . Then  $2qx + py$  is

A)  $p^2 - q$

B)  $2p^3$

C)  $-2q^3$

D)  $p^2 + q^2$

E)  $p^3 - q^3$

80. If  $z = x + iy$  and  $|z+1| = |z-4|$ . Then the equation of locus of  $z$  is

A)  $x = 2y$

B)  $x - 3y = 0$

C)  $x = \frac{3}{2}$

D)  $y = \frac{2}{3}$

E)  $y = \frac{1}{2}$

81. If  $3-i$  is a root of  $x^2 - 6x + c = 0$ . Where  $c$  is a real number, the value of  $c$  is  
 A)  $-8$                       B)  $10$                       C)  $18$                       D)  $-6$                       E)  $3$
82. If  $|z_1| = 3, |z_2| = 4$  and  $k = |z_1 + z_2|$ . Then which of the following is correct  
 A)  $0 \leq k \leq 7$             B)  $-1 \leq k \leq 7$             C)  $1 \leq k \leq 7$             D)  $3 \leq k \leq 8$             E)  $3 \leq k \leq 4$
83. The principal argument of the complex number  $z = \frac{1 + \sin 2\pi - i \cos \pi}{1 + \sin 2\pi + i \cos \pi}$  is  
 A)  $\frac{\pi}{3}$                       B)  $\frac{\pi}{6}$                       C)  $\frac{\pi}{5}$                       D)  $\frac{\pi}{2}$                       E)  $\frac{\pi}{4}$
84. Let  $z_1 = 1 + 4i$  and  $z_2 = 2 - 8i$ . Then  $|z_1 \cdot z_2|$  is  
 A)  $\sqrt{17}$                       B)  $2\sqrt{17}$                       C)  $34$                       D)  $2\sqrt{34}$                       E)  $17$
85. In an AP, the sum of first and third terms is 6 and sum of second and fourth terms is 20. Then the 11<sup>th</sup> term is  
 A)  $67$                       B)  $62$                       C)  $57$                       D)  $73$                       E)  $66$
86. If  $x = 1 + a + a^2 + \dots \infty$  and  $y = 1 + b + b^2 + \dots \infty$  where  $a$  and  $b$  are proper fractions, then  $1 + ab + a^2b^2 + \dots \infty$  equals  
 A)  $\frac{xy}{x+y-1}$                       B)  $\frac{x+y}{x-y}$                       C)  $\frac{x^2+y^2}{x-y}$   
 D)  $\frac{x}{x-y}$                       E)  $\frac{x-y}{x}$
87. The sum of  $n$  terms of an AP is  $3n^2 + n$ ,  $r^{\text{th}}$  term 292. The value of  $r$  is  
 A)  $82$                       B)  $46$                       C)  $52$                       D)  $49$                       E)  $48$
88. The number of positive integers less than 1000 having only odd digits is  
 A)  $155$                       B)  $177$                       C)  $55$                       D)  $85$                       E)  $205$
89.  $13C_0 + 13C_1 + 13C_2 + 13C_3 + 13C_4 + 13C_5 + 13C_6$   
 A)  $2^{10}$                       B)  $2^{11}$                       C)  $2^{13}$                       D)  $2^{12}$                       E)  $2^7$
90. The sum of coefficients in the expansion of  $(1 + 3x - x^2)^{24}$  is  
 A)  $2^{24}$                       B)  $3^{20}$                       C)  $3^{24}$                       D)  $2^{23}$                       E)  $3$
91. Middle term in the expansion of  $\left(x - \frac{1}{x}\right)^8$  is  
 A)  $8C_4$                       B)  $-8C_4$                       C)  $8C_5$                       D)  $8C_6$                       E)  $-8C_3$
92. The number of ways a committee of 3 people can be chosen from a panel of 9 people is  
 A)  $90$                       B)  $64$                       C)  $72$                       D)  $84$                       E)  $63$

93. If  $A = \begin{bmatrix} 3 & 4 \\ -2 & 6 \end{bmatrix}$  and  $A - B = \begin{bmatrix} 2 & 2 \\ -10 & 10 \end{bmatrix}$ , then  $B =$
- A)  $\begin{bmatrix} 1 & 2 \\ 8 & 4 \end{bmatrix}$       B)  $\begin{bmatrix} -1 & 2 \\ 8 & -4 \end{bmatrix}$       C)  $\begin{bmatrix} 1 & 2 \\ -8 & 4 \end{bmatrix}$       D)  $\begin{bmatrix} 1 & 2 \\ 8 & -4 \end{bmatrix}$       E)  $\begin{bmatrix} -1 & -2 \\ 8 & -4 \end{bmatrix}$
94. If the square of the matrix  $\begin{bmatrix} a & b \\ a & -a \end{bmatrix}$  is the unit matrix, then  $b$  is equal to
- A)  $\frac{a}{1+a^2}$       B)  $\frac{1-a^2}{a}$       C)  $\frac{1+a^2}{a}$       D)  $\frac{a}{1-a^2}$       E)  $1+a^2$
95. If  $A = \begin{bmatrix} 2 & 2 \\ 2 & 2 \end{bmatrix}$ , then  $A^{100}$
- A)  $2^{199}A$       B)  $2^{99}A$       C)  $2^{198}A$       D)  $2^{100}A$       E)  $200A$
96. Let  $A$  and  $B$  be  $3 \times 3$  symmetric matrices such that  $X = AB + BA$  and  $Y = AB - BA$ , then  $(X.Y)^T$  is equal to
- A)  $X.Y$       B)  $Y.X$       C)  $-XY$       D)  $-YX$       E)  $X^2Y$
97. If  $a, b, c, d$  are positive real numbers such that  $a + b + c + d = 2$ , then  $M = (a + b)(c + d)$  satisfies the relation
- A)  $0 < M \leq 1$       B)  $1 \leq M \leq 2$       C)  $2 \leq M < 3$       D)  $3 \leq M \leq 4$       E)  $1 \leq M \leq 3$
98. If  $6 \leq x \leq 8$ , then
- A)  $(x - 6)(x - 8) \geq 0$       B)  $(x - 6)(8 - x) \geq 0$
- C)  $(x - 6)(x - 8) > 0$       D)  $(6 - x)(x - 8) \leq 0$       E)  $x - 8 \leq 0$
99. If  $A + B = C$ . Then  $\tan A \cdot \tan B \cdot \tan C$  is
- A)  $\tan C - \tan A + \tan B$       B)  $\tan C - \tan A - \tan B$
- C)  $\tan C + \tan A + \tan B$       D)  $\tan A - \tan B - \tan C$
- E)  $\tan A + \tan B - \tan C$
100. If  $\tan x + \tan y = \frac{7}{9}$  and  $\cot x + \cot y = 7$ , then  $\tan(x + y)$  is
- A)  $\frac{7}{8}$       B)  $\frac{8}{9}$       C)  $\frac{7}{9}$       D)  $7$       E)  $9$
101. If  $\tan 2\theta \cdot \tan \theta = 1$ , then  $\theta =$
- A)  $n\pi + \frac{\pi}{6}$       B)  $n\pi \pm \frac{\pi}{6}$       C)  $2n\pi \pm \frac{\pi}{6}$       D)  $n\pi \pm \frac{\pi}{3}$       E)  $2n\pi \pm \frac{\pi}{3}$

102.  $\cot\left[\cos^{-1}\left(\frac{7}{25}\right)\right]$  is
- A)  $\frac{25}{24}$       B)  $\frac{25}{7}$       C)  $\frac{24}{25}$       D)  $\frac{7}{24}$       E)  $\frac{25}{48}$
103. Equation of straight line whose x intercept and y intercept are 3, -2 respectively
- A)  $2x + 3y = 6$       B)  $2x - 3y = 6$       C)  $-2x + 3y = 6$       D)  $2x + 3y = -6$       E)  $3x - 2y = 6$
104. The equation of the line passing through the point  $(-7, 7)$  with slope zero is
- A)  $x = -7$       B)  $y = -7$       C)  $y = 7$       D)  $y = 0$       E)  $x = 0$
105. The line  $y = 2x + c$  touches the parabola  $y^2 = 8x$  then c is
- A) 1      B) 2      C)  $\frac{1}{2}$       D) 4      E) 3
106. If  $(a, 2)$  is the point of intersection of the straight lines  $y = 2x - 4$  and  $y = x + c$ , then the value of C is equal to
- A) -1      B) 3      C) -2      D) -3      E) 1
107. The maximum value of  $z = 7x + 5y$  subject to  $2x + y \leq 100, 4x + 3y \leq 240, x \geq 0, y \geq 0$
- A) 350      B) 380      C) 400      D) 410      E) 420
108. The equation of the circle whose radius is  $\sqrt{7}$  and concentric with the circle  $x^2 + y^2 - 8x + 6y - 11 = 0$  is
- A)  $x^2 + y^2 - 8x + 6y + 7 = 0$       B)  $x^2 + y^2 - 8x + 6y + 18 = 0$   
C)  $x^2 + y^2 - 8x + 6y - 4 = 0$       D)  $x^2 + y^2 - 8x + 6y - 18 = 0$   
E)  $x^2 + y^2 - 8x + 6y - 7 = 0$
109. The equation of the circle with centre at  $(1, 1)$  and touching the line  $3x + 4y + 3 = 0$  is
- A)  $x^2 + y^2 - 2x - 2y + 2 = 0$       B)  $x^2 + y^2 - 2x - 2y - 2 = 0$   
C)  $x^2 + y^2 + 2x + 2y + 2 = 0$       D)  $x^2 + y^2 + 2x + 2y + 4 = 0$   
E)  $x^2 + y^2 + 2x + 2y - 4 = 0$
110. Length of latus rectum of the parabola  $3y^2 = x$  is
- A)  $\frac{1}{3}$       B) 3      C) 1      D) 2      E)  $\frac{1}{2}$
111. The eccentricity of the ellipse  $x^2 + \frac{y^2}{8} = 1$  is
- A)  $\frac{7}{8}$       B) 4      C)  $\frac{\sqrt{7}}{2\sqrt{2}}$       D)  $\frac{\sqrt{7}}{\sqrt{4}}$       E)  $\frac{8}{7}$

112. The latus rectum of the hyperbola  $3x^2 - 2y^2 = 12$  is

- A)  $\frac{4}{\sqrt{2}}$       B)  $\frac{\sqrt{3}}{2}$       C)  $\frac{8}{\sqrt{3}}$       D) 6      E)  $\frac{12}{\sqrt{2}}$

113. Direction cosine of the vector  $\hat{i} - 2\hat{j} + 3\hat{k}$  is

- A)  $\left(\frac{1}{\sqrt{14}}, \frac{-2}{\sqrt{14}}, \frac{3}{\sqrt{14}}\right)$       B)  $\left(\frac{2}{\sqrt{14}}, \frac{-2}{\sqrt{11}}, \frac{3}{\sqrt{14}}\right)$       C)  $\left(\frac{1}{\sqrt{7}}, \frac{-2}{\sqrt{7}}, \frac{3}{\sqrt{7}}\right)$   
 D)  $\left(\frac{1}{\sqrt{14}}, \frac{+2}{\sqrt{14}}, \frac{3}{\sqrt{14}}\right)$       E)  $\left(\frac{1}{2\sqrt{7}}, \frac{1}{\sqrt{7}}, \frac{3}{2\sqrt{7}}\right)$

114. The value of a so that  $|a\hat{i} + (a+1)\hat{j} + 2\hat{k}| = 3$  are

- A) 2, -4      B) 1, 2      C) -1, 2      D) -2, 4      E) 1, -2

115. If  $|\vec{a}| = 2$ ,  $|\vec{b}| = 3$  and  $\vec{a} \cdot \vec{b} = 5$ , then  $|\vec{a} - \vec{b}|$  is equal to

- A) 3      B) 5      C)  $\sqrt{5}$       D)  $\sqrt{6}$       E)  $\sqrt{3}$

116. Which one of the following points lies on the straight line  $\frac{x-1}{2} = \frac{y+1}{4} = \frac{z-2}{-2}$  is

- A) (2, 6, -2)      B) (4, 3, 1)      C) (3, 4, -1)      D) (6, 2, -1)      E) (3, 3, 0)

117. If  $\tan^{-1} x + \tan^{-1} y = \frac{2\pi}{3}$ , then  $\cot^{-1} x + \cot^{-1} y$  is equal to

- A)  $\frac{\pi}{2}$       B)  $\frac{1}{2}$       C)  $\frac{\pi}{3}$   
 D)  $\frac{\sqrt{3}}{2}$       E)  $\pi$

118. The distance between the directrices of the hyperbola  $x^2 - y^2 = 9$  is

- A)  $\frac{9}{\sqrt{2}}$       B)  $\frac{5}{\sqrt{3}}$       C)  $\frac{3}{\sqrt{2}}$       D)  $3\sqrt{2}$       E)  $5\sqrt{3}$

119. If the semi-major axis of an ellipse is 3 and the latusrectum is  $\frac{16}{9}$ , then the standard equation of the ellipse is

- A)  $\frac{x^2}{9} + \frac{y^2}{8} = 1$       B)  $\frac{x^2}{8} + \frac{y^2}{9} = 1$       C)  $\frac{x^2}{9} + \frac{3y^2}{8} = 1$   
 D)  $\frac{3x^2}{8} + \frac{y^2}{9} = 1$       E)  $\frac{x^2}{9} + \frac{8y^2}{3} = 1$

120. The angle between the lines  $\frac{x-1}{1} = \frac{y-3}{2} = \frac{z-4}{3}$  and  $\frac{x+1}{4} = \frac{y-5}{2} = \frac{z-3}{1}$

A)  $\cos^{-1}\left(\frac{11}{\sqrt{14 \times 21}}\right)$       B)  $\cos^{-1}\left(\frac{\sqrt{11}}{\sqrt{14 \times 21}}\right)$       C)  $\cos^{-1}\left(\frac{11}{\sqrt{21}}\right)$

D)  $\cos^{-1}\frac{11}{\sqrt{14}}$       E)  $\cos^{-1}\left(\frac{\sqrt{11}}{14 \times 21}\right)$

121. The probability that a leap year selected at random will contain either 53 Thursdays or 53 Fridays

A)  $\frac{1}{7}$       B)  $\frac{2}{7}$       C)  $\frac{3}{7}$       D)  $\frac{4}{7}$       E)  $\frac{5}{7}$

122. If  $P(A) = \frac{1}{4}$ ,  $P\left(\frac{A}{B}\right) = \frac{1}{2}$  and  $P\left(\frac{B}{A}\right) = \frac{2}{3}$ . Then  $P(B)$  is

A)  $\frac{1}{2}$       B)  $\frac{1}{6}$       C)  $\frac{1}{3}$       D)  $\frac{2}{3}$       E)  $\frac{1}{4}$

123.  $f(x) = \begin{cases} x-2, & x > 3 \\ x^2-4, & x \leq 3 \end{cases}$  Then the value of  $f(-3)$  is

A) 4      B) 5      C) 13      D) -5      E) 6

124. If  $y = \frac{x+x^2+2x^4}{x}$ . Then  $\frac{dy}{dx}$  is

A)  $1+6x^2$       B)  $1+12x^3$       C)  $1+4x^2$       D)  $1-3x^2$       E)  $x+12x^3$

125. If  $y = \sin t$ . Then  $\frac{dy}{dx}$  is

A)  $\cos t$       B)  $\sin t$       C)  $\cos t \frac{dt}{dx}$       D)  $\sin t \frac{dt}{dx}$       E)  $\tan t$

126.  $\lim_{x \rightarrow 2} \left[ \frac{\sin(x-2)}{x^2-5x+6} \right]$  is

A) 0      B) -1      C) 2  
D) -3      E) does not exist

127. Let  $f(x) = \begin{cases} ax^3-4x & x > 3 \\ 2x+4 & x \leq 3 \end{cases}$   $f$  is continuous at  $x=3$ . Then the value of  $a$  is

A)  $\frac{27}{22}$       B)  $\frac{24}{27}$       C)  $\frac{22}{27}$       D)  $\frac{12}{27}$       E)  $\frac{34}{47}$

128.  $\lim_{x \rightarrow 0} \frac{x^{102} \cdot \sin 5x}{(\sin x)^{103}}$  is equal to

- A)  $\frac{1}{5}$       B)  $\frac{1}{2}$       C)  $-\frac{1}{5}$       D) 5      E) -5

129. If  $y = x^x$ . Then  $\frac{dy}{dx}$  is

- A)  $x^x(1 + \log(x))$     B)  $1 + \log(x)$     C)  $x^x(1 - \log(x))$   
 D)  $x^x(1 - \log(x^2))$     E)  $x^x + x^x \log(x^x)$

130. If  $x^2 + 2xy + y^2 = 4$  Then  $\frac{dy}{dx}$  at (1,1) is

- A) -1      B) 0      C) 1      D) 2      E) -3

131. Let  $f(x) = \begin{cases} 4x^2, & x \leq 2 \\ 3, & 2 < x < 4 \\ 10 + 3x, & x \geq 4 \end{cases}$ . Then  $f'(10)$  is

- A) -10      B) 3      C) 2      D) 1      E) 4

132. The equation of tangent to the curve  $y = 3x^2 - 4x + 1$  at  $x = 2$  is

- A)  $4x + y - 3 = 0$       B)  $4x - y - 3 = 0$   
 C)  $4x + y + 3 = 0$       D)  $8x - y + 21 = 0$       E)  $8x - y - 11 = 0$

133. If  $f(x) = \sin^4 x + \cos^4 x$ . Then

- A)  $f(x) \geq 2$       B)  $1 < f(x) \leq 2$       C)  $\frac{1}{2} \leq f(x) \leq 1$   
 D)  $\frac{3}{4} \leq f(x) \leq 1$       E)  $\frac{1}{4} \leq f(x) \leq \frac{1}{2}$

134.  $\int a^x da$  is

- A)  $\frac{a^x}{\log a} + c$     B)  $\frac{a^x}{2 \log(a)} + c$     C)  $\frac{a^{x+1}}{x+1} + c$     D)  $\frac{a^x}{x} + c$     E)  $a^x \log(a) + c$

135.  $\int \sin^3 x dx =$

- A)  $\frac{\cos^3 x}{3} - \cos x + c$     B)  $\frac{\sin^3 x}{3} - \cos x + c$     C)  $\frac{\sin^3 x}{3} + \sin x + c$   
 D)  $\frac{\sin^4 x}{4} - \cos x + c$     E)  $\frac{\sin^2 x}{2} - \cos x + c$

136.  $\int \frac{1}{1-x} dx =$

A)  $\log(1-x) + c$

B)  $\log x + c$

C)  $-\log(1-x) + c$

D)  $\frac{\log(x)}{x} + c$

E)  $\log(x^2 + x) + c$

137.  $\int \log(x) dx =$

A)  $x \log\left(\frac{x}{e}\right) + c$

B)  $x \log(x) - 1 + c$

C)  $\log(x) - x + c$

D)  $\log(x) - \log e + c$

E)  $\log(x) + \log e + c$

138.  $\int \frac{2x^3}{1+x^2} dx =$

A)  $x^2 + \log(1+x^2) + c$

B)  $x^2 - \log(1+x^2) + c$

C)  $\log(1+x^2) + c$

D)  $\log(1+x^2) - x^2 + c$

E)  $\log(1+x^2) - \log(x^2) + c$

139. The integrating factor of the differential equation  $3x^2 \frac{dy}{dx} - xy = 4x^3$

A)  $\frac{1}{x^3}$

B)  $\frac{1}{x^{2/3}}$

C)  $x^{-3}$

D)  $\frac{-1}{x^3}$

E)  $\frac{1}{x}$

140. Degree of differential equation  $\sin\left(\frac{d^2y}{dx^2}\right) - \frac{dy}{dx} = 0$

A) 2

B) 1

C) 3

D) not defined

E) 0

141.  $\int_0^{2\pi} \sqrt{\cos^2 x} dx =$

A) 0

B) 2

C) -4

D) 4

E) 1

142.  $\int_{-\frac{\pi}{2}}^{\frac{\pi}{2}} [2x^3 + x^5 + 4x^7 + \cos x] dx$

A) 0

B) -1

C) 2

D) 4

E) 1

143.  $\int_{-5}^5 |x| dx =$

A)  $\frac{25}{2}$

B) 25

C) 10

D) 50

E) 15

144.  $\int \cos\left(\frac{x}{2}-1\right) dx =$

A)  $2 \sin\left(\frac{x}{2}-1\right) + c$

B)  $2 \cos\left(\frac{x}{2}-1\right) + c$

C)  $\frac{1}{2} \cos\left(\frac{x}{2}-1\right) + c$

D)  $\frac{1}{2} \sin\left(\frac{x}{2}-1\right) + c$

E)  $\frac{-1}{2} \cos\left(\frac{x}{2}-1\right) + c$

145. Area bounded by the curve  $y = |x|$ ,  $y = 0$ ,  $x = 2$  and  $x = -2$  is

A) 2 sq.unit

B) 4 sq.unit

C) 3 sq unit

D) 6 sq unit

E) 1 sq unit

146. The area enclosed by the curve  $x = 3 \cos \theta$ ,  $y = 2 \sin \theta$ ,  $0 \leq \theta \leq \pi$  is (in square units)

A)  $9\pi$

B)  $6\pi$

C)  $4\pi$

D)  $3\pi$

E)  $2\pi$

147.  $\int \left[ e^x \log(x) + \frac{e^x}{x} \right] dx =$

A)  $e^x \log(x) + c$

B)  $\frac{e^x}{x} + c$

C)  $e^x x + c$

D)  $\frac{\log(x)}{x} + c$

E)  $\log(x) + e^x + c$

148.  $\int \frac{1}{x(x^5+1)} dx =$

A)  $\frac{1}{5} \log|x^5+1| + c$

B)  $\frac{1}{5} \log \left| \frac{x^5}{x^5+1} \right| + c$

C)  $3 \log \left| \frac{x^5}{x^5+1} \right| + c$

D)  $5 \log \left| \frac{x^5+1}{x^5} \right| + c$

E)  $\frac{1}{5} \log \left| \frac{x^5+1}{x^5} \right| + c$

149.  $\int \frac{1}{x^2-4} dx =$

A)  $\frac{1}{4} \log \left| \frac{x-4}{x+4} \right| + c$

B)  $\frac{1}{2} \log \left| \frac{x-2}{x+2} \right| + c$

C)  $\frac{1}{4} \log \left| \frac{x-2}{x+2} \right| + c$

D)  $\frac{1}{4} \log \left| \frac{x+2}{x-2} \right| + c$

E)  $\frac{1}{2} \log \left| \frac{x+2}{x-2} \right| + c$

150.  $\int \tan^{-1}(x) dx =$

A)  $x \tan^{-1}(x) - \log(1+x^2)$

B)  $\tan^{-1}(x) - \frac{1}{2} \log(1+x^2) + c$

C)  $x \tan^{-1}(x) - \log(x) + c$

D)  $x \tan^{-1}(x) - \frac{1}{2} \log(1+x^2) + c$

E)  $x \tan^{-1}(x) + \frac{1}{2} \log(1+x^2) + c$

PHYSICS

1. C  $g = 4\pi^2 \frac{\ell}{T^2} \frac{\Delta g}{g} \times 100 = \frac{\Delta \ell}{\ell} \times 100 + 2 \frac{\Delta T}{T} \times 100$

2. B Sum : same decimal places as the number having least decimal places.  
Division: same no. of significant figures as the number having least no. of decimal places.

3. A  $a = v \frac{dv}{dx} = k\sqrt{x} \times k \times \frac{1}{2\sqrt{x}} = \frac{k^2}{2}$  (constant)

4. E  $h = \frac{u^2}{2g} \Rightarrow 2h = \frac{2u^2}{2g} = \frac{(\sqrt{2}u)^2}{2g} \therefore v = \sqrt{2}u$

$$\frac{v-u}{u} \times 100 = \frac{\sqrt{2}u - u \times 100}{u} = \frac{1.414 - 1}{1} \times 100 = 41.4\%$$

5. E

6. B The vertical component of velocity of particle is negative, meaning it has already passed the maximum height.

7. C

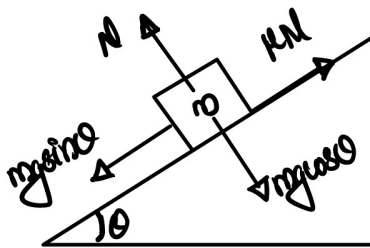

limiting equilibrium:  $mg \sin \theta = \mu N = \mu mg \cos \theta$

$$\tan \theta = \mu \text{ or } \theta = \tan^{-1}(\mu)$$

8. B Common acceleration of system,  $a = \left( \frac{10-5}{10+5} \right) \times 10 = \frac{10}{3} \text{ m/s}^2$

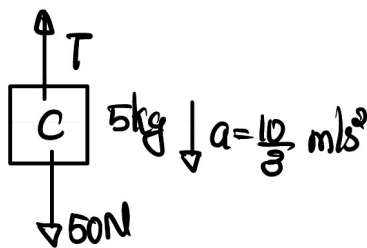

From the FBD of block C,  $50 - T = 5 \times \frac{10}{3}$

$$T = 50 - \frac{50}{3} = 50 \times \frac{2}{3} = \frac{100}{3} \text{ N} = 33.33 \text{ N}$$

9. E

10. B Momentum gained by block = J; Kinetic energy gained by block =  $\frac{J^2}{2m}$

By conservation of energy,  $\frac{J^2}{2m} = \frac{1}{2} kx^2 \Rightarrow x^2 = \frac{J^2}{km} \Rightarrow x = \frac{J}{\sqrt{km}}$

11. E  $I_0 = I_{10} + I_{20} = \frac{m\ell^2}{3} + \frac{m\ell^2}{3} = \frac{2m\ell^2}{3}$

12. A  $K_{\text{rot}} = \frac{1}{2} I \omega^2 = \frac{1}{2} \left( \frac{2}{5} MR^2 \right) \omega^2 = \frac{1}{5} \left( \frac{4}{3} \pi R^3 \rho \right) R^2 \omega^2 = \frac{4}{15} \pi R^5 \rho \omega^2$

13. D By conservation of energy,  $-\frac{GMm}{R+h} = \frac{1}{2}mv^2 - \frac{GMm}{R} \Rightarrow \frac{V^2}{2} = GM\left(\frac{1}{R} - \frac{1}{R+h}\right)$   
 $v^2 = 2Gm\left(\frac{1}{R} - \frac{1}{2R}\right) = \frac{GM}{R} = \frac{gR^2}{R} = gR \Rightarrow v = \sqrt{gR}$

14. E

15. B  $y = \frac{\text{stress}}{\text{strain}} = \text{slope of stress - strain graph}$

$$Y_A = \tan 60^\circ = \sqrt{3} \quad Y_B = \tan 30^\circ = \frac{1}{\sqrt{3}} \quad Y_A Y_B = 1$$

16. E  $\frac{X-20}{C-0} = \frac{200-20}{100-0} \Rightarrow \frac{X-20}{C} = \frac{9}{5} \Rightarrow X-20 = \frac{9C}{5} \Rightarrow X = \frac{9}{5}C + 20$   
 $X = C \Rightarrow C = \frac{9C}{5} + 20 \Rightarrow -\frac{4}{5}C = 20 \Rightarrow C = -25^\circ\text{C} \text{ or } X = -25^\circ\text{C}$

17. D  $W = \frac{1}{2} \times 10V_0 \times 4P_0 = 20P_0V_0$   
 $T_A = \frac{P_A V_A}{R} = \frac{P_0 V_0}{R} \quad T_B = \frac{P_B V_B}{R} = \frac{55P_0 V_0}{R} \quad \Delta T = T_B - T_A = \frac{54P_0 V_0}{R} \Rightarrow P_0 V_0 = \frac{R\Delta T}{54}$

$$\therefore W = 20 \times \frac{R\Delta T}{54} = \frac{10R\Delta T}{27}$$

$$\Delta U = nC_v \Delta T = \frac{3}{2} R\Delta T$$

$$Q = \Delta U + W = \frac{3}{2} R\Delta T + \frac{10R\Delta T}{27} = \frac{101R}{54} \Delta T$$

$$\therefore Q = nC\Delta T, C = \frac{101R}{54}$$

18. E  $V_{\text{rms}} = \sqrt{\frac{3RT}{M}} \Rightarrow V_{\text{rms}} \propto \frac{1}{\sqrt{M}}$

19. C  $U_{\text{max}} = \frac{1}{2} kA^2 \Rightarrow K = \frac{2U_{\text{max}}}{A^2} = \frac{2 \times 10}{4 \times 10^{-6}} = 5 \times 10^6 \text{ N/m}$

20. C  $\lambda = \frac{2\pi}{k} = \frac{2\pi}{\frac{\pi}{80}} = 160\text{cm}$

$$\lambda = \frac{4\ell}{2n-1} \Rightarrow 2n-1 = \frac{4 \times 200}{160} = 5 \Rightarrow 2n = 6 \Rightarrow n = 3$$

21. E  $f_b = f_2 - f_1 = 54 - 50 = 4\text{Hz} \quad T = \frac{1}{f_b} = 0.25\text{s}$

22. E

23. B A dipole placed in a non-uniform electric field experience a net force in the direction in which the decrease in potential energy is steepest.

24. C  $V_A - V_B = -\int_{\vec{r}_B}^{\vec{r}_A} \vec{E} \cdot d\vec{r} = -E(x_A - x_B) = -20(-3 - 2) = 100\text{V}$

25. D

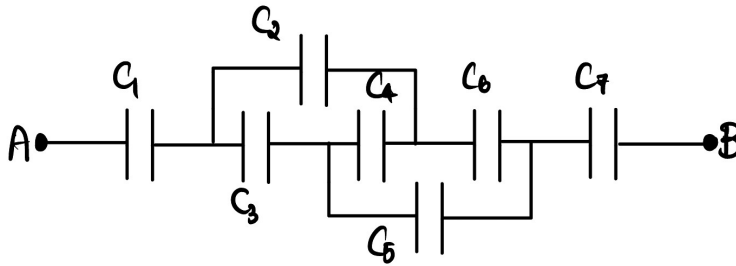

Capacitors \$C\_2\$ to \$C\_6\$ form a balanced wheatstone's bridge. \$C\_4\$ can be removed. \$C\_2 \parallel C\_3\$ and \$C\_5 \parallel C\_6\$, \$C\_1\$ and \$C\_7\$ in series with \$C\_2 \parallel C\_3\$ and \$C\_5 \parallel C\_6\$

26. A

27. B

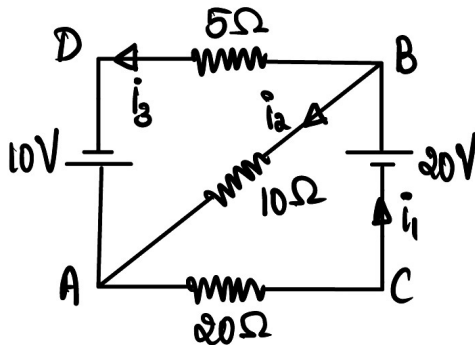

KVL for loop ACBA :  $-20i_1 + 20 - 10i_2 = 0 \Rightarrow 2i_1 + i_2 = 2 \rightarrow (1)$

KVL for loop BDAB :  $-5i_3 + 10 + 10i_2 = 0 \Rightarrow i_3 - 2i_2 = 2 \rightarrow (2)$

KCL at node B :  $i_1 = i_2 + i_3 \rightarrow (3)$

(3) & (1) gives  $2i_3 + 3i_2 = 10 \rightarrow (4)$

(2) & (4) gives  $i_2 = \frac{6}{7} \text{ A}$

$\therefore V_B - 10i_2 = V_A \Rightarrow V_A - V_B = 10i_2 = -10 \times \frac{6}{7} = -8.6 \text{ V}$

28. E  $\sigma = \frac{ne^2\tau}{m} \Rightarrow \sigma\alpha\tau$

29. C  $\vec{F} = q(\vec{E} + \vec{V} \times \vec{B}) = \vec{0}$  if

i)  $E = 0$  and  $B = 0$

ii)  $E = 0$  and  $B \neq 0$  such that  $\vec{V} \times \vec{B} = \vec{0}$

iii)  $E \neq 0$  and  $B \neq 0$  such that  $\vec{E} + (\vec{V} \times \vec{B}) = \vec{0}$

30. A For loop AODEA,  $\vec{M}_1 = I\vec{A}_1 = 10 \times 50 \times 10^{-4} \hat{j} = 5 \times 10^{-2} \hat{j} \text{ A.m}^2$

For loop OACD0,  $\vec{M}_2 = I\vec{A}_2 = 10 \times 25 \times 10^{-4} \hat{i} = 2.5 \times 10^{-2} \hat{i} \text{ Am}^2$

Resultant dipole moment:  $\vec{M} = \vec{M}_1 + \vec{M}_2 = \frac{5}{2} \times 10^{-2} (\hat{i} + 2\hat{j}) \text{ A.m}^2 \quad n = \frac{5\sqrt{5}}{2} \times 10^{-2} \text{ A.m}^2$

31. A

32. C

33. E  $\ell$  is parallel to B. So, motioned emf = 0

34. E

35. A  $I = \frac{V}{R} = \frac{20}{100} = 0.2A$

$$U_B = \frac{1}{2}hI^2 = \frac{1}{2} \times 2 \times 10^{-3} \times 4 \times 10^{-2} = 4 \times 10^{-5}J$$

36. E

37. C  $\frac{V_s}{V_p} = \frac{N_s}{N_p} = \frac{5}{2} \Rightarrow V_s = \frac{5}{2} \times 100 = 250V$

38. B  $n = \frac{C}{V} = \frac{3}{2}$   $n = \sqrt{\mu\epsilon_r} \Rightarrow \epsilon_r = n^2 = \frac{9}{4}$

39. E  $n = \frac{\sin i}{\sin r} = \frac{\sin(2r)}{\sin r} = 2 \cos r \Rightarrow \cos r = \frac{n}{2} = \frac{\sqrt{2}}{2} = \frac{1}{\sqrt{2}} \Rightarrow r = 45^\circ$

$$A = r_1 + r_2 = 2r = 90^\circ$$

40. B

$$I = \frac{I_0}{2} \cos^2 30^\circ = \frac{I_0}{2} \times \frac{3}{4} = \frac{3}{8} I_0$$

41. A 
$$\left. \begin{aligned} E &= \frac{hc}{\lambda} - \phi \\ 2E &= \frac{hc}{\lambda'} - \phi \end{aligned} \right\} \rightarrow E = hc \left( \frac{1}{\lambda'} - \frac{1}{\lambda} \right) \Rightarrow \frac{1}{\lambda'} = \frac{1}{\lambda} + \frac{E}{hc} = \frac{R\lambda + hc}{hc\lambda} \Rightarrow \lambda' = \frac{hc\lambda}{E\lambda + hc}$$

42. D  $\frac{1}{\lambda_{\max}} = R \left( \frac{1}{2^2} - \frac{1}{3^2} \right) = \frac{5R}{36} \Rightarrow \lambda_{\max} = \frac{36}{5R} \frac{\lambda_{\max}}{\lambda_{\min}} = \frac{9}{5}$

$$\frac{1}{\lambda_{\min}} = R \left( \frac{1}{2^2} - 0 \right) = \frac{R}{4} \Rightarrow \lambda_{\min} = \frac{4}{R}$$

43. E

44. A

45. D

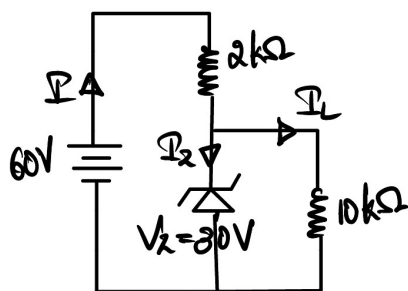

$$I_L = \frac{30}{10 \times 10^3} = 3mA$$

$$I = \frac{30}{2 \times 10^3} = 15mA$$

$$I_z = I - I_L = 15 - 3 = 12mA$$

**CHEMISTRY**

46. B

47. C

48. D All radioactive reactions are first order reactions

49. A

50. C

51. B 
$$E_{\text{Mg}^{2+}|\text{Mg}}^{\ominus} = E_{\text{Mg}^{2+}|\text{Mg}} + \frac{0.059}{2} \log [\text{Mg}^{2+}]$$

$$y = c + mx$$

52. C

53. C

54. A

55. C We know  $\Delta_r G^{\ominus} = -2.303 RT \log K_p$  and  
 $R = 8.314 \text{ JK}^{-1} \text{ mol}^{-1}$   
 Therefore,  $\Delta_r G^{\ominus} =$   
 $-2.303 (8.314 \text{ J K}^{-1} \text{ mol}^{-1})$   
 $\times (298 \text{ K}) (\log 2.47 \times 10^{-29})$   
 $= 163000 \text{ J mol}^{-1}$   
 $= 163 \text{ kJ mol}^{-1}$ .

56. A The conjugate bases should have one proton less in each case and therefore the corresponding conjugate bases are:  $\text{F}^-$ , \_\_\_\_\_  
 $\text{HSO}_4^-$  and  $\text{CO}_3^{2-}$  respectively.

57. B

58. D 
$$r_n = \frac{a_0 n^2}{Z}$$

For first orbit of hydrogen  $r_1 = a_0$   
 $\therefore$  For  $\text{Be}^{3+} \rightarrow r_2 = \frac{a_0 \times 2^2}{4} = a_0$

59. D For  $\text{N}_2$  molecule  $\sigma 1s < \sigma^* 1s < \sigma 2s < \sigma^* 2s (\pi 2p_x = \pi 2p_y) < \sigma 2p_z$   
 $< (\pi^x 2p_x = \pi^x 2p_y) < \sigma^* 2p_z$

60. C

61. A According to Le-Chatelier's principle, at constant temperature, the equilibrium composition will change but  $K$  will remain same.

62. B

63. A

64. D Salt solution acidified with dilute  $\text{HNO}_3$  on addition of silver nitrate solution gives a curdy white precipitate soluble in ammonium hydroxide solution. This indicates the presence of  $\text{Cl}^-$  ions in the salt. \_\_\_\_\_

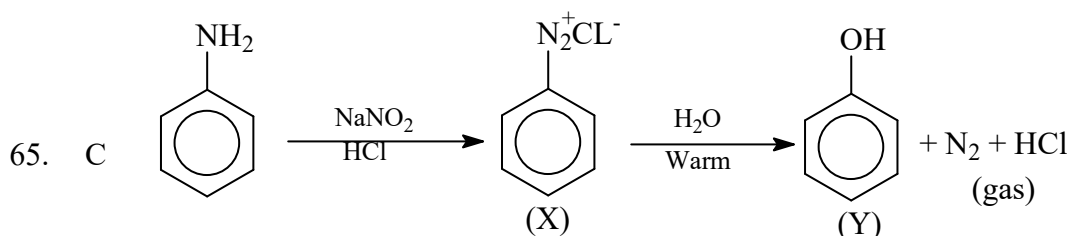

66. D As the acidic strength  $\uparrow$   $\text{pK}_a$  value decreases

67. C

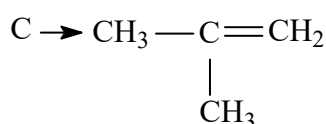
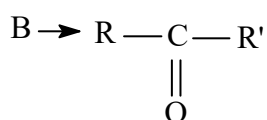
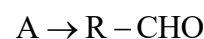

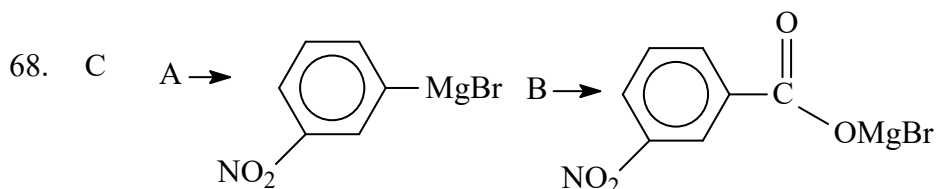

69. B Benzene diazonium fluoroborate is water insoluble

70. C

71. C

72. B

73. B

74. A

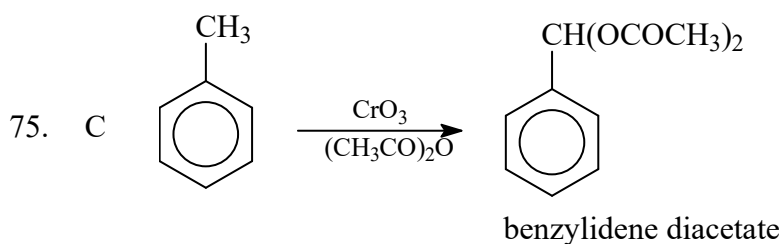

**MATHEMATICS**

76. A

77. C

78. C

79. C

80. C  $z = x + iy \quad \sqrt{z} = p - iq \Rightarrow z = (p - iq)^2$   
 $x + iy = p^2 - q^2 - 2pqi ; \Rightarrow x = p^2 - q^2, y = -2pq$   
 $2qx + py = 2q(p^2 - q^2) + p \times -2pq = 2p^2q - 2q^3 - 2p^2q = -2q^3$

81. B

82. C  $\left| |z_1| - |z_2| \right| \leq |z_1 + z_2| \leq |z_1| + |z_2|$

83. D

84. C

85. E

86. A

87. D

88. A

89. D  ${}^{13}C_0 + {}^{13}C_1 + {}^{13}C_2 + \dots + {}^{13}C_{13} = 2^{13}$   
 ${}^{13}C_0 = {}^{13}C_{13}, {}^{13}C_1 = {}^{13}C_{12}, {}^{13}C_2 = {}^{13}C_{11}$   
 ${}^{13}C_3 = {}^{13}C_{10}, {}^{13}C_4 = {}^{13}C_9, {}^{13}C_5 = {}^{13}C_8, {}^{13}C_6 = {}^{13}C_7$   
 $\therefore {}^{13}C_0 + {}^{13}C_1 + {}^{13}C_2 + \dots + {}^{13}C_{13} = 2({}^{13}C_0 + {}^{13}C_1 + {}^{13}C_2 + \dots + {}^{13}C_6) = 2^{13}$   
 $\Rightarrow {}^{13}C_0 + {}^{13}C_1 + {}^{13}C_2 + \dots + {}^{13}C_6 = \frac{2^{13}}{2} = 2^{12}$

90. C

91. A

92. D

93. D

94. B

95. C

96. D

97. A

98. B

99. B  $C = A + B$ 

$$\tan C = \tan(A + B) = \frac{\tan A + \tan B}{1 - \tan A \tan B}$$

$$\tan C = \frac{\tan A + \tan B}{1 - \tan A \tan B} \Rightarrow \tan C(1 - \tan A \tan B) = \tan A + \tan B$$

$$\tan C - \tan C \tan A \tan B = \tan A + \tan B$$

$$\tan C - \tan A - \tan B = \tan A \tan B \tan C$$

100. A  $\tan x + \tan y = \frac{7}{9}$   $\cot x + \cot y = 7$ 

$$\Rightarrow \frac{1}{\tan x} + \frac{1}{\tan y} = 7; \quad \frac{\tan y + \tan x}{\tan x \tan y} = 7 \Rightarrow \tan y + \tan x = 7 \tan x \tan y$$

$$= \frac{7}{9} = 7 \tan x \tan y \Rightarrow \tan x \tan y = \frac{1}{9}$$

$$\tan(x + y) = \frac{\tan x + \tan y}{1 - \tan x \tan y} = \frac{\frac{7}{9}}{1 - \frac{1}{9}} = \frac{\frac{7}{9}}{\frac{8}{9}} = \frac{7}{8}; \quad \tan(x + y) = \frac{7}{8}$$

101. B

102. D

103. B

104. C

105. A  $C = \frac{a}{m} \therefore C = \frac{2}{2} = 1$ 

106. A

107. D

108. B

109. B

110. A

111. C

112. D

113. A

114. E

115. E

116. E

117. C  $\tan^{-1} x + \tan^{-1} y = \frac{2\pi}{3}$ 

$$\frac{\pi}{2} - \cot^{-1} x + \frac{\pi}{2} - \cot^{-1} y = \frac{2\pi}{3}; \quad \cot^{-1} x + \cot^{-1} y = \pi - \frac{2\pi}{3} = \frac{\pi}{3}$$

118. D Distance between directrices =  $\frac{2a}{e}$ ; Here  $e = \sqrt{2}$ ;  $\therefore$  distance =  $\frac{2 \times 3}{\sqrt{2}} = 3\sqrt{2}$ 119. C  $\frac{2b^2}{a} = \frac{16}{9} \Rightarrow b^2 = \frac{8}{3}; \quad \frac{x^2}{9} + \frac{3y^2}{8} = 1$ 

120. A

121. C

122. C

123. B  
124. A  
125. C

$$126. B \quad \lim_{x \rightarrow 2} \frac{\sin(x-2)}{(x^2-5x+6)} = \lim_{x \rightarrow 2} \frac{\sin(x-2)}{(x-3)(x-2)} = \lim_{x \rightarrow 2} \frac{\sin(x-2)}{x-2} \times \frac{1}{(x-3)} = 1 \times \frac{1}{-1} = -1$$

127. C

$$128. D \quad \lim_{x \rightarrow 0} \frac{x^{102} \cdot \sin 5x}{(\sin x)^{103}} = \lim_{x \rightarrow 0} \frac{x^{103} \sin 5x}{(\sin x)^{103} \cdot x} = \lim_{x \rightarrow 0} \frac{1}{\left[\frac{(\sin x)}{x}\right]^{103}} \times \frac{\sin 5x}{5x} \times 5$$

$$= \lim_{x \rightarrow 0} \frac{1}{\left(\frac{\sin x}{x}\right)^{103}} \times 5 \lim_{x \rightarrow 0} \left(\frac{\sin 5x}{5x}\right) = \frac{1}{1} \times 5 \times 1 = 5$$

129. A

$$130. A \quad x^2 + 2xy + y^2 = 4; \quad (x+y)^2 = 4 \Rightarrow x+y = 2; \quad 1 + \frac{dy}{dx} = 0 \Rightarrow \frac{dy}{dx} = -1$$

131. B  
132. E

$$133. C \quad \sin^4 x + \cos^4 x = 1 - 2 \sin^2 x \cos^2 x$$

134. C

$$135. A \quad \int \sin^3 x dx = \int \sin^2 x \cdot \sin x dx = \int (1 - \cos^2 x) \sin x dx; \text{ Put } t = \cos x; -dt = \sin x dx$$

$$= \int (1 - t^2) - dt = \int (t^2 - 1) dt = \frac{t^3}{3} - t + c = \frac{\cos^3 x}{3} - \cos x + c$$

136. C  
137. A

$$138. B \quad \int \frac{2x^3}{1+x^2} dx = \int \frac{2x \cdot x^2}{1+x^2} dx \quad \text{Put } t = x^2$$

$$dt = 2x dx = \int \frac{t}{1+t} dt = \int \frac{t+1-1}{1+t} dt = \int \left(1 - \frac{1}{1+t}\right) dt = t - \log(1+t) + c = x^2 - \log(1+x^2) + c$$

139. D  
140. D

$$141. D \quad \int_0^{2\pi} \sqrt{\cos^2 x} dx = \int_0^{2\pi} |\cos x| dx = 4$$

142. C  
143. B  
144. A  
145. B  
146. D  
147. A

$$148. B \quad \int \frac{1}{x(x^n+1)} dx = \frac{1}{n} \log \left( \frac{x^n}{x^n+1} \right) + c$$

149. C

$$150. D \quad \int \tan^{-1}(x) dx = \tan^{-1}(x) \cdot \int 1 dx - \int \frac{1}{1+x^2} x dx = x \tan^{-1}(x) - \frac{1}{2} \int \frac{2x}{1+x^2} dx$$

$$= x \tan^{-1}(x) - \frac{1}{2} \log(1+x^2) + c$$